

IOM 200

CAN bus analogue interface

Data sheet

4921240366D



1. General information

1.1 Applications	3
1.2 Overview	3
1.2.1 Terminals.....	4
1.2.2 Analogue output DIP switches.....	4
1.2.3 IOM ID DIP switches.....	5

2. Technical Information

2.1 CAN bus connections	6
2.2 Technical specifications	6
2.2.1 Available variants.....	6
2.2.2 Specifications.....	6
2.2.3 Unit dimensions in mm (inches).....	8

3. Ordering Information

3.1 Order specifications	9
3.2 Disclaimer	9

1. General information

1.1 Applications

AGC-4 Mk II, AGC 150 and AGC 200 use CAN bus to communicate with the IOM 200 series.

Each IOM 220 has two analogue outputs that can be used for control. IOM 230 also has P and Q load sharing outputs (these can only be used with AGC 150 and AGC 200).

For each analogue output, the signal type (mA, or V DC) and the range can be selected using dip switches. The analogue output V DC signal levels can be adjusted using the potentiometer screws.

Controller	Functions	Max. IOM 2xx	IOM ID	Terminals 7-8	Terminals 9-10	IOM 230 only Terminals 12-14
AGC-4 Mk II	General purpose PID control	3	0/1/2	A01	A02	-
AGC 150, AGC 200	General purpose PID control	2	1/2	PID	PID	-
AGC 150, AGC 200	Genset regulation	1	0	GOV	AVR	Q and P load sharing

1.2 Overview

IOM 220

- CANbus interface with automatic address selection
- Analogue output/governor interface
 - 0-20 mA
 - ±25 mA
 - 0-10 V DC (adjustable)
 - ±12 V DC (adjustable)
- Analogue output/AVR interface
 - 0-20 mA
 - ±25 mA
 - 0-10 V DC (adjustable)
 - ±12 V DC (adjustable)
- TTL interface to PC
 - Uses option J5 (RS232 to TTL converter cable)
 - Only for downloading firmware updates
- LEDs for unit status and CAN status
 - 2-coloured LEDs
 - Green: System OK; Red: Fail

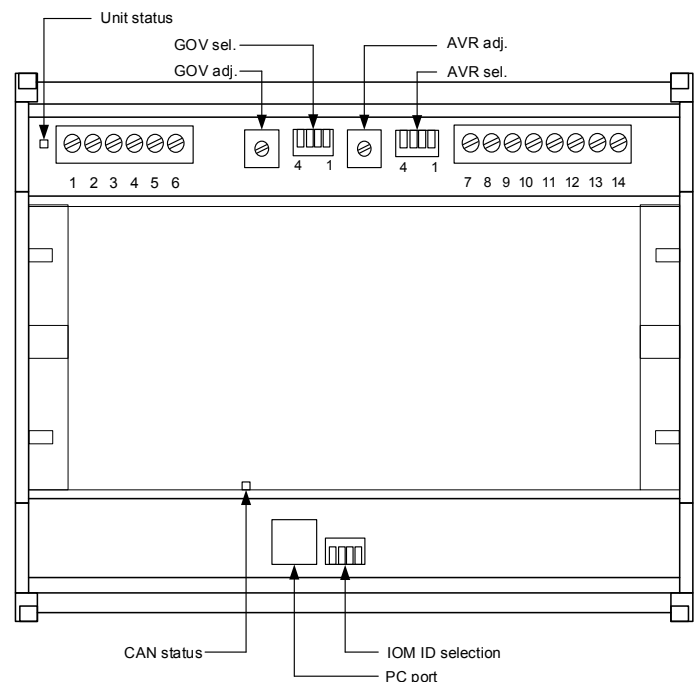

IOM 230

Same as IOM 220, with additional:

- Analogue Q and P load sharing interface (-5 ... 0 ... +5 V DC)

1.2.1 Terminals

IOM 200

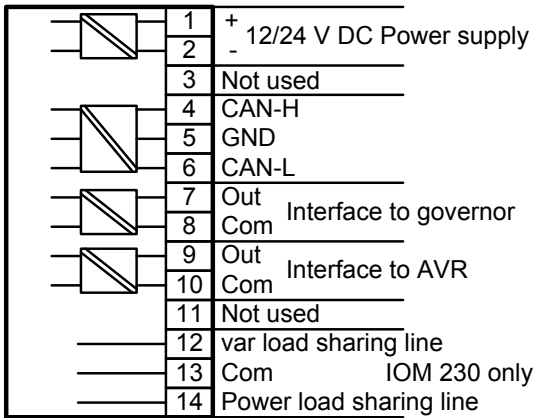

Terminal	Description	Comment
1	+12/24 V DC	Power supply
2	0 V DC	
3	Not used	
4	CAN-H	CANbus interface to AGC
5	CAN-GND	
6	CAN-L	
7	GOV out	Analogue output/Governor interface
8	GOV com	
9	AVR out	Analogue output/AVR interface
10	AVR com	
11	Not used	
12	VAr share out	IOM 230 only: Load sharing lines (AGC 150/AGC 200 only)
13	Common	
14	P share out	

1.2.2 Analogue output DIP switches

	Output	SW 1	SW 2	SW 3	SW 4
	±25 mA	ON	OFF	NOT USED	OFF
	0-20 mA	OFF	ON		OFF
	±12V DC	ON	OFF		ON
	0-10V DC	OFF	ON		ON

SW 1 and SW 2 cannot have the same position. The output resolution is 1024 steps, regardless of the selected range.

1.2.3 IOM ID DIP switches

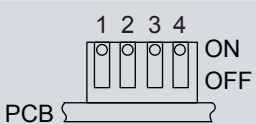
	IOM ID	Switch 1	Switch 2	Switch 3	Switch 4
 PCB	ID0	OFF	OFF	OFF	OFF
	ID1	ON	OFF	OFF	OFF
	ID2	OFF	ON	OFF	OFF

All other combinations = ID0.

2. Technical Information

2.1 CAN bus connections

The CAN bus connection can be "point-to-point" between an IOM 200 module and an AGC, or "multi-drop" between an AGC, IOM 200 and an engine controller. In both cases, the cable shield must NOT be connected to ground, but only to the GND terminal of the IOM and AGC.

Point-to-point

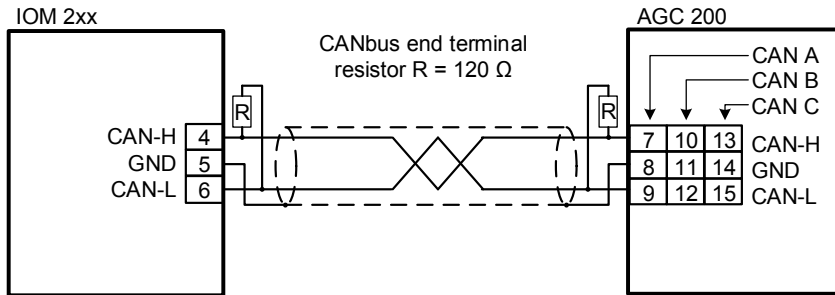

Multi-drop

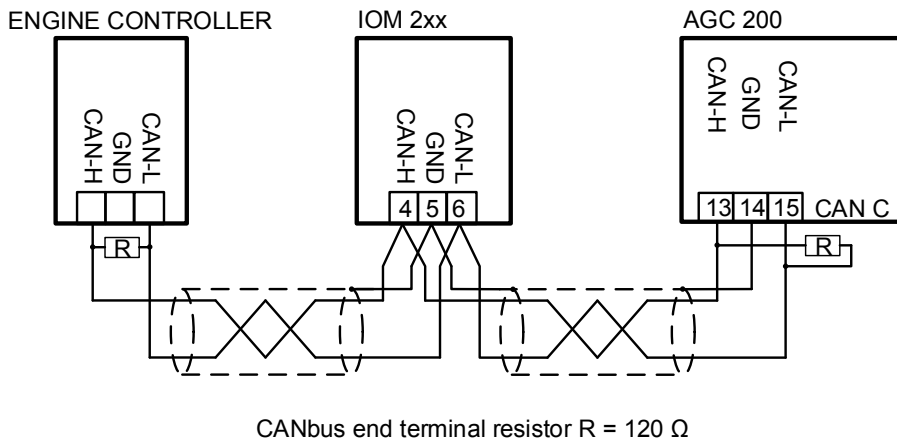

For multi-drop, the cable shield must NOT be connected to the engine controller unless it is absolutely certain that the engine controller CAN bus connection is galvanically isolated from the rest of the controller.

2.2 Technical specifications

2.2.1 Available variants

Type	Variant	Description	Item no.	Note
IOM 200	01	IOM 220	2912890200-01	Two analogue outputs/GOV and AVR outputs
IOM 200	02	IOM 230	2912890200-02	Two analogue outputs/GOV and AVR outputs and (AGC 150/AGC 200 only) P and Q loadshare lines

2.2.2 Specifications

Operating temperature	-40...70°C (-40...158°F) UL/cUL Listed: Max. surrounding air temperature: 55°C (131°F)
Storage temperature	-40...70°C (-40...158°F)

Climate	97% RH to IEC 60068-2-30
Aux. supply	8.5-36V DC continuously (UL/cUL: 8.5...32.7V DC) Max. 4 W consumption The aux. supply input is to be protected by a 2 A slow-blow fuse (UL/cUL listed: AWG 24)
Mounting	DIN rail
Safety	To EN 61010-1, installation category (overvoltage category) III, 300V, pollution degree 2
Protection	IP20/NEMA type 1 to IEC/EN 60529
EMC/CE	To EN 61000-6-1/2/3/4 IEC 60255-26 IEC 60533 power distr. zone IACS UR E10 power distr. zone
Vibration	3...13.2 Hz: 2mm _{pp} 13.2...100 Hz: 0.7 g To IEC 60068-2-6 To IACS UR E10 10...60 Hz: 0.15mm _{pp} 60...150 Hz: 1 g To IEC 60255-21-1 Response (class 2) 10..150 Hz: 2 g To IEC 60255-21-1 Endurance (class 2)
Shock	10 g, 11 msec, half sine To IEC 60255-21-2 Response (class 2) 30 g, 11 msec, half sine To IEC 60255-21-2 Endurance (class 2) 50 g, 11 msec, half sine To IEC 60068-2-27
Bump	20 g, 16 msec, half sine to IEC 60255-21-2 (class 2)
Material	All plastic materials are self-extinguishing according to UL 96 (V1)
Connections	3.5 mm ² (13 AWG) multi-stranded service port: TTL, RJ 12
Tightening torque (min)	0.5 Nm (5-7 lb-in)
Approvals	UL/cUL Listed to UL508 UL/cUL Recognized to UL2200
UL markings	Wiring: Use 60/75°C copper conductors only
Mounting	For DIN rail mounting inside a cabinet Main disconnect must be provided by installer Installation: To be installed in accordance with the NEC (US) or the CEC (Canada)
Weight	0.3 kg (0.7 lbs)

2.2.3 Unit dimensions in mm (inches)

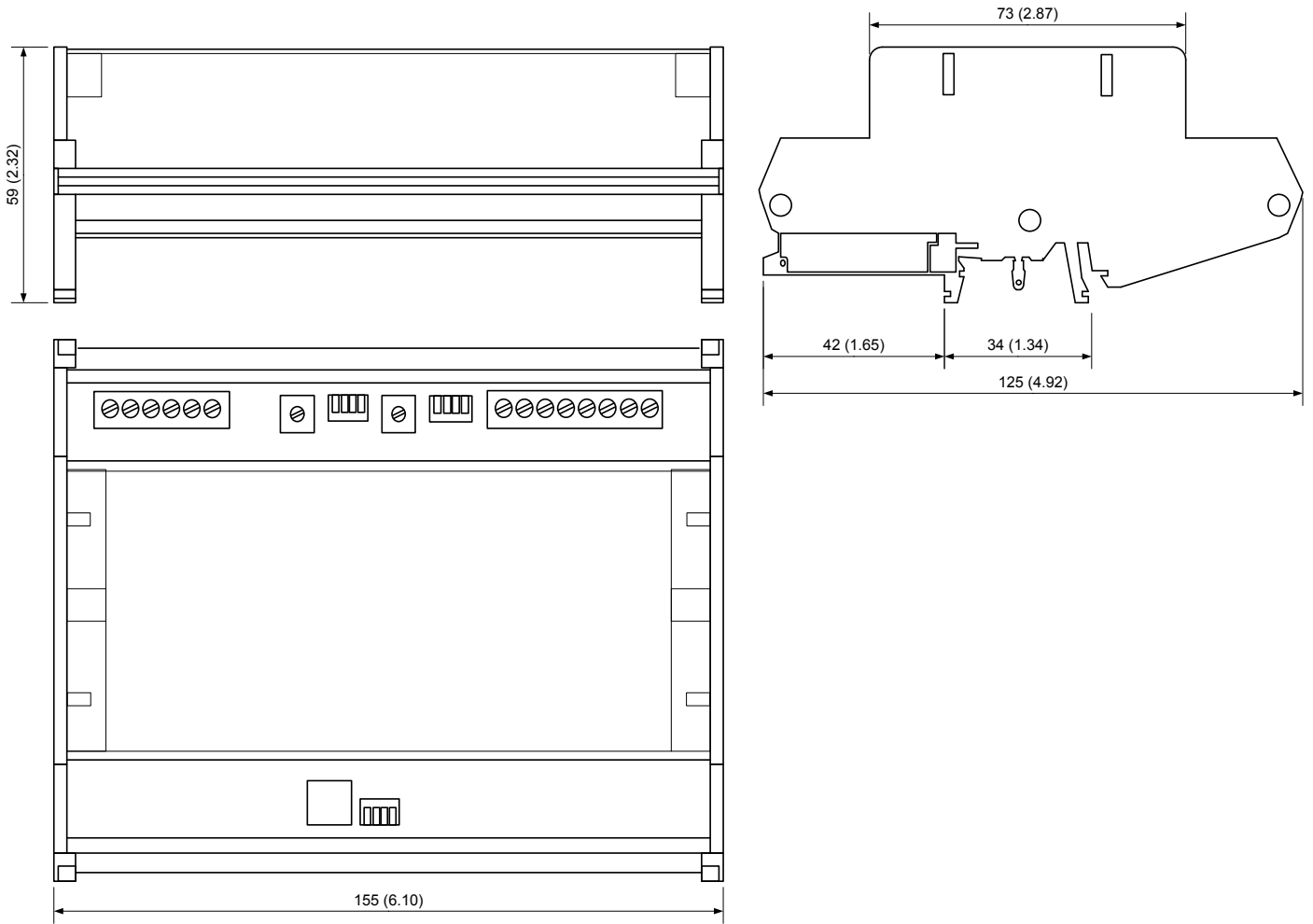

3. Ordering Information

3.1 Order specifications

Variants:

Mandatory information		
Item no.	Type	Variant no.

Example:

Mandatory information		
Item no.	Type	Variant no.
2912890200-01	IOM 220	01

3.2 Disclaimer

DEIF A/S reserves the right to change any of the contents of this document without prior notice.

The English version of this document always contains the most recent and up-to-date information about the product. DEIF does not take responsibility for the accuracy of translations, and translations might not be updated at the same time as the English document. If there is a discrepancy, the English version prevails.