

# Acuvim II Series Intelligent Power Meter (Web Accessible)



Revenue Grade with **DATA-LOGGING**  
and **WAVEFORM CAPTURE**



ISO9001 Certified



## DESCRIPTION

The Acuvim II series are high-end multifunction power and energy meters manufactured by Accuenergy. They are the ideal choice for the monitoring and controlling of power distribution systems. Some of the features and electrical power parameters available on the Acuvim II series are:

- True-RMS Measuring Parameter
- ANSI C12.20(0.2 Class) and IEC 62053-22(0.2S Class)
- Power Quality Analysis
- Over/Under Limit Alarm
- Multi Communication Ports (Eg: Ethernet, RS485)
- Web Server and Email Sending
- Switch Status Monitoring
- Waveform Capture

- Measure Individual Harmonics from 2<sup>nd</sup> to 63<sup>rd</sup> (Acuvim IIR/IIE/IIW)
- Module Design
- Data-Logging
- TOU, 4 Tariffs, 12 Seasons, 14 Schedules
- Class Leading Warranty

The Acuvim II series may be used as data gathering devices for intelligent power distribution systems or plant automation systems. All monitored data is available via a digital RS485 communication port running Modbus RTU protocol. Ethernet and Profibus DP communication are also options.

With its flexible, modular I/O and communication options, the Acuvim II series is the most versatile and cost-effective metering solution on the market.

## Acuvim II Series Meters

● Function; ○ Option; Blank NA

CATEGORY	ITEM	PARAMETERS	Acuvim II	Acuvim IIR	Acuvim IIE	Acuvim IIW	
METERING	REAL TIME METERING	Phase Voltage	V1, V2, V3, Vlnavg	●	●	●	●
		Line Voltage	V12, V23, V31, Vllavg	●	●	●	●
		Current	I1, I2, I3, In, Iavg	●	●	●	●
		Power	P1, P2, P3, Psum	●	●	●	●
		Reactive Power	Q1, Q2, Q3, Qsum	●	●	●	●
		Apparent Power	S1, S2, S3, Ssum	●	●	●	●
		Power Factor	PF1, PF2, PF3, PF	●	●	●	●
		Frequency	F	●	●	●	●
		Load Features	Load Features	●	●	●	●
	Four Quadrant Powers	Four Quadrant Powers	●	●	●	●	
	ENERGY & DEMAND	Energy	Ep_imp, Ep_exp, Ep_total, Ep_net	●	●	●	●
		Reactive Energy	Eq_imp, Eq_exp, Eq_total, Eq_net	●	●	●	●
		Apparent Energy	Es	●	●	●	●
		Demand	Dmd_P, Dmd_Q, Dmd_S, Dmd_I1, Dmd_I2, Dmd_I3	●	●	●	●
TOU	TIME OF USE	Energy/max demand	TOU, 4 Tariffs, 12 Seasons, 14 Schedules				
	DAYLIGHT SAVING TIME	Two formats adjust	Month/Day/Hour/Minute Month/Week/First few weeks/Hour/Minute				
MONITORING	Waveform Capture	voltage and current Waveform	Trigger, Manual, DI change, Sag/Dips, Swell, Over Current				
	POWER QUALITY	Voltage Unbalance Factor	U_unbl	●	●	●	●
		Current Unbalance Factor	I_unbl	●	●	●	●
		Voltage THD	THD_V1, THD_V2, THD_V3, THD_Vavg	●	●	●	●
		Current THD	THD_I1, THD_I2, THD_I, THD_Iavg	●	●	●	●
		Individual Harmonics	Harmonics 2 <sup>nd</sup> to 63 <sup>rd</sup> (31 <sup>st</sup> for Acuvim II)	●	●	●	●
		Voltage Crest Factor	Crest Factor	●	●	●	●
		TIF	THFF	●	●	●	●
	Current K factor	K Factor	●	●	●	●	
	STATISTICS	MAX with Time Stamp	Each phase of V & I; Total of P, Q, S, PF & F; Demad of P, Q & S;	●	●	●	●
MIN with Time Stamp		Each phase THD of V & I; Unbalance factor of V & I	●	●	●	●	
OTHERS	ALARM	Over/Under Limit Alarm	●	●	●	●	
	POWER QUALITY EVENT LOGGING	SAG/DIPS, SWELL	Voltage				
	DATA LOGGING	Data Logging 1	F, V1/2/3/Iavg, V12/23/13/Iavg, I1/2/3/n/avg, P1/2/3/sum, Q1/2/3/sum, S1/2/3/sum, PF1/2/3, PF, U_unbl, I_unbl, Load Type, Ep_imp, Ep_exp, Ep_total, Ep_net, Eq_imp, Eq_exp, Eq_total, Eq_net, Es, THD_V1/2/3/avg, THD_I1/2/3/avg, Harmonics 2nd to 63rd, Crest Factor, THFF, K Factor, sequence and phase angles, DI counter, AI, AO, Dmd P/Q/S, Dmd I1/2/3	●	●	●	●
		Data Logging 2		●	●	●	●
		Data Logging 3		●	●	●	●
	ONBOARD MEMORY SIZE	Memory	Bytes	—	4MB	4MB	8MB
COMMUNICATION	RS485 Port, Half Duplex, Optical Isolated	Modbus <sup>®</sup> -RTU Protocol	●	●	●	●	
TIME	Real Time Clock	Year, Month, Date, Hour, Minute, Second	●	●	●	●	
OPTION MODULE	I/O OPTION	Switch Status (DI)	Digital Input (Wet)	○	○	○	○
		Power Supply for DI	24 Vdc	○	○	○	○
		Relay Output (RO)	NO, Form A	○	○	○	○
		Digital Output (DO)	Photo-MOS	○	○	○	○
		Pulse Output (PO)	By using DO	○	○	○	○
		Analog Input (AI)	0(4)~20mA, 0(1)~5V	○	○	○	○
	COMMUNICATION	Analog Output (AO)	0(4)~20mA, 0(1)~5V	○	○	○	○
		Ethernet	10M/100M, Modbus-TCP, HTTP Webpage, Email	○	○	○	○
		Profibus-DP	Profibus-DP/V0	○	○	○	○
		RS485 Module	Additional Modbus RTU	○	○	○	○

## I/O Module (Option)

Module Name	Digital Input (DI)	Power Supply For DI (24V)	Digital Output (DO)	Relay Output (RO)	Analog Input (AI)	Analog Output (AO)
AXM-IO1	6	1		2		
AXM-IO2	4		2			2
AXM-IO3	4			2	2	

## Communication Module (Option)

Module Name	Spec		
AXM-NET	10M/100M self-adaptable, RJ45 Jack HTTP Web page browser	Modbus®-TCP/IP Protocol Email sending on time interval or on event	
AXM-PROFI	Profibus-DP/V0 Profibus slave mode, baud rate self-adaptable up to 12M	Input Byte (typical): 32 byte Output Byte (typical): 32 Byte	EN50170 vol.2 compliance
AXM-RS485	Modbus®-RTU Protocol		

## APPLICATIONS

- Metering of distribution feeders, transformers, generators, capacitor banks and motors
- Medium and low voltage systems
- Commercial, industrial, utility
- Power quality analysis
- Data Logging

## FEATURES

### Metering

- Voltage V1, V2, V3, Vlnav, V12, V23, V31, Vllav
- Current I1, I2, I3, In, lav
- Power P1, P2, P3, Psum
- Reactive Power Q1, Q2, Q3, Qsum
- Apparent Power S1, S2, S3, Ssum
- Frequency F
- Power Factor PF1, PF2, PF3, PF
- Energy Ep\_imp, Ep\_exp, Ep\_total, Ep\_net
- Reactive Energy Eq\_imp, Eq\_exp, Eq\_total, Eq\_net
- Apparent Energy Es
- Demand Dmd\_P, Dmd\_Q, Dmd\_S, Dmd\_I1, Dmd\_I2, Dmd\_I3
- Load Features
- Four Quadrant Powers

### Monitoring

- Power Quality
- Voltage Harmonics 2<sup>nd</sup> to 63<sup>rd</sup> and THD
- Current Harmonics 2<sup>nd</sup> to 63<sup>rd</sup> and THD
- Voltage Crest Factor
- THFF (TIF)
- Current K Factor
- Voltage Unbalance Factor U\_unbl
- Current Unbalance Factor I\_unbl
- Max/Min Statistics with Time Stamps
- Sampling rate 128 samples per cycle

### Alarms

Limits can be set for up to 16 indicated parameters and can be set with a specified time interval. If any input of the indicated parameters is over or under its setting limit and persists over the specified time interval, the event will be recorded with time stamps and trigger the Alarm DO output. The 16 indicated parameters can be selected from any of the 51 parameters available.

### I/O option module

The E-module® technique was adopted for its flexibility and easy expansion of the I/O function of Acuvim II. A maximum of 3 modules can be used for one meter. Digital input, digital output, pulse output, relay output, analog input and analog output are provided by I/O option module.

### Communication

Modbus RTU protocol via RS485  
Ethernet (Modbus TCP, HTTP, SMTP)  
Profibus DP  
Dual RS485 communication ports

### Display

Clear and large character LCD Screen display with white back light  
Wide environmental temperature endurance  
Display Load percentage, 4 quadrants power and load nature

### Outline

Small Size 96×96 DIN or 4" ANSI Round

### Data Logging

Acuvim IIR/IIIE/IIW offers 3 assignable historical logs where the majority of the metering parameters can be recorded. The onboard memory is up to 8 MB and each log size is adjustable. A real time clock allows for any logged events to be accurately time stamped.

### Time of use

User can assign up to 4 different tariffs (sharp, peak, valley and normal) to different time periods within a day according to the billing requirements. The meter will calculate and accumulate energy to different tariffs according to the meter's internal clock timing and TOU settings.

### Waveform Capture

Acuvim IIW can record 8 groups of voltage and current waveforms. It provides the waveform record of 8 cycles before and after the triggering point. It also supports a settable triggering condition.

### Power Quality Event Logging

When a power quality event happens, such as voltage sag and swell, etc., Acuvim IIW will record the timestamp and the triggering condition of the event. It can save up to 50,000 power quality events.

## TYPICAL WEB PAGE FROM Acuvim II SERIES

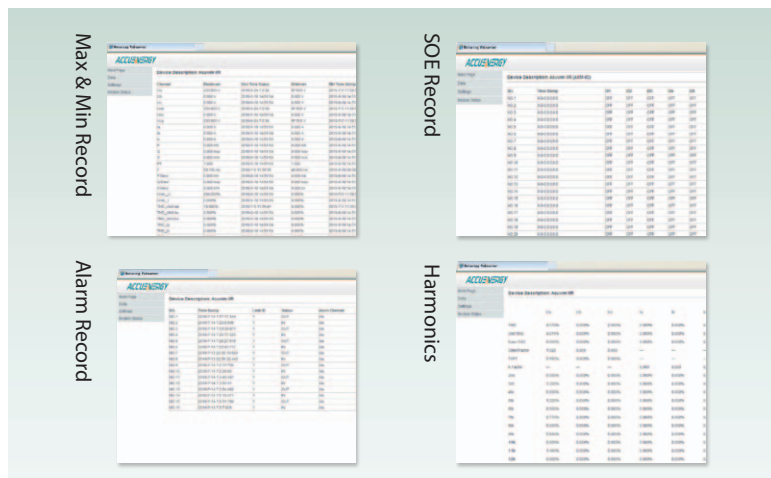

The image displays four screenshots of the Acuvim II web interface, each showing a data table with various parameters and their values over time. The screenshots are labeled as follows:

- Max & Min Record:** Shows a table with columns for time, voltage, current, power, and other parameters, listing maximum and minimum values.
- SOE Record:** Shows a table with columns for time, event type, and description, listing Sequence of Events.
- Alarm Record:** Shows a table with columns for time, alarm type, and description, listing triggered alarms.
- Harmonics:** Shows a table with columns for time, harmonic order, and magnitude, listing harmonic distortion data.

## DATA LOGGING FROM Acuvim II SERIES

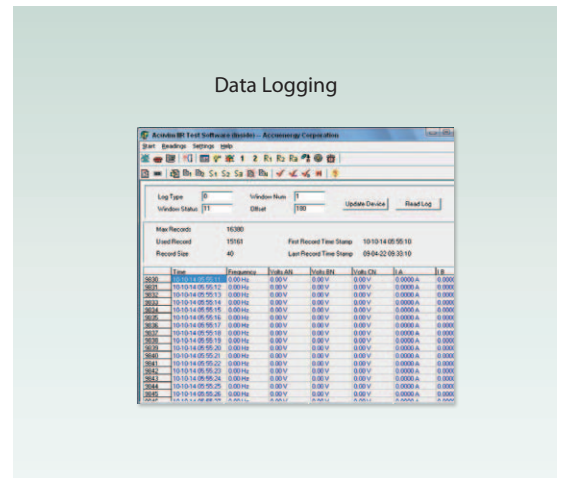

The image shows a screenshot of the Acuvim II web interface for data logging configuration and data display. The configuration section includes:

- Log Type:** Selection buttons for Voltage, Current, Power, etc.
- Update Status:** A dropdown menu set to 'All'.
- Update Device:** A button to refresh the data.
- Read Log:** A button to view the log data.
- Max Records:** 10000
- Used Record:** 1561
- Record Size:** 40
- First Record Time Stamp:** 10/10/14 08:55:10
- Last Record Time Stamp:** 08/04/2015 08:30:10

Below the configuration is a data table with columns: Time, Parameters, Units, Units, Units, Units, Units, Units, Units. The table contains multiple rows of logged data points.

## SPECIFICATIONS

### METERING

Parameters	Accuracy		Resolution	Range	
	Acuvim II	Acuvim IIR/IE/IIW			
Voltage	0.2%	0.2%	0.1V	20V~1000kV	
Current	0.2%	0.2%	0.1mA	5mA~50000A	
Power	0.5%	0.2%	1W	-9999MW~9999MW	
Reactive Power	0.5%	0.2%	1var	-9999Mvar~9999Mvar	
Apparent Power	0.5%	0.2%	1VA	0~9999MVA	
Power Demand	0.5%	0.2%	1W	-9999MW~9999MW	
Reactive Power Demand	0.5%	0.2%	1var	-9999Mvar~9999Mvar	
Apparent Power Demand	0.5%	0.2%	1VA	0~9999MVA	
Power Factor	0.5%	0.2%	0.001	-1.000~1.000	
Frequency	0.2%	0.2%	0.01Hz	45.00~65.00Hz	
Energy	Primary	0.5%	0.2%	0.1kWh	0-99999999.9kWh
	Secondary	0.5%	0.2%	0.001kWh	0-999999.999kWh
Reactive Energy	Primary	0.5%	0.2%	0.1kvarh	0-99999999.9kvarh
	Secondary	0.5%	0.2%	0.001kvarh	0-999999.999kvarh
Apparent Energy	Primary	0.5%	0.2%	0.1kVAh	0-99999999.9kVAh
	Secondary	0.5%	0.2%	0.001kVAh	0-999999.999kVAh
Harmonics	1.0%	1.0%	0.1%	0.0%~100.0% 20.0%~100.0% (IIR/IE/IIW)	
Phase Angle	2.0%	2.0%	0.1°	0.0°~359.9°	
Unbalance Factor	2.0%	2.0%	0.1%	0.0%~100.0%	
Running Time			0.01h	0~9999999.99h	

### INPUT

#### Current Inputs (Each Channel)

Nominal Current	5A /1A
Metering Range	0~10A ac
Withstand	20Arms continuous, 100Arms for 1 second, non-recurring
Burden	0.05VA (typical) @ 5Arms
Pickup Current	0.1% of nominal
Accuracy	0.2% full scale

#### Voltage Inputs (Each Channel)

Nominal Full Scale	400Vac L-N, 690Vac L-L (+20%)
Withstand	1500Vac continuous 2500Vac, 50/60Hz for 1 minute
Input Impedance	2Mohm per phase
Metering Frequency	45Hz~65Hz
Pickup Voltage	10Vac (30 Vac for Acuvim IIR/IE/IIW)
Accuracy	0.2% full scale

#### Energy Accuracy (Acuvim IIR/IE/IIW)

Active (according to IEC 62053-22)	Class 0.2s
(according to ANSI C12.20)	Class 0.2s
Reactive (according to IEC 62053-23)	Class 2

#### Harmonic Resolution

Metered Value	Acuvim II: 31 <sup>st</sup> harmonic Acuvim IIR/IE/IIW: 63 <sup>rd</sup> harmonic
---------------	--

### COMMUNICATION

#### RS-485 (Standard)

MODBUS® RTU Protocol, 2-wire connection  
1200~38400 baud rate

#### The Second RS-485 Port (Optional)

MODBUS® RTU Protocol, 2-wire connection  
4800~38400 baud rate

#### Ethernet (Optional)

10M/100M BaseT  
MODBUS® TCP/IP Protocol  
Data Browsing through HTTP  
Sending e-mail automatically

#### PROFI-BUS (Optional)

PROFIBUS-DP/V0 Protocol  
Work as PROFIBUS slave, baud rate adaptive, up to 12M  
Typical input bytes: 32, typical output bytes: 32  
PROFIBUS standard according to EN 50170 vol.2

### CONTROL POWER

Universal	AC or DC
<b>AC/DC Control Power</b>	
Operating Range	100~415Vac, 50/60Hz; 100~300Vdc
Burden	5W
Frequency	50/60Hz
Withstand	3250Vac, 50/60Hz for 1 minute
Installation Category III (Distribution)	
<b>Low Voltage DC Control Power (Optional)</b>	
Operating Range	20~60Vdc
Burden	5W

### I/O OPTION

#### Digital Input

Input Voltage Range	20~160 Vac/dc
Input Current (Max)	2mA
Start Voltage	15V
Stop Voltage	5V
Pulse Frequency (Max)	100Hz, 50% Duty Ratio (5ms ON and 5ms OFF)
SOE Resolution	2ms

#### Digital Output (DO) (Photo-MOS)

Voltage Range	0~250Vac/dc
Load Current	100mA (Max)
Output Frequency	25Hz, 50% Duty Ratio (20ms ON, 20ms OFF)
Isolation Voltage	2500Vac

#### Relay Output (RO)

Switching Voltage (Max)	250Vac, 30Vdc
Load Current	5A(R), 2A(L)
Set Time	10ms (Max)
Contact Resistance	30mΩ (Max)
Isolation Voltage	2500Vac
Mechanical Life	1.5x10 <sup>7</sup>

#### Analog Output (AO)

Output Range	0~5V/1~5V, 0~20mA/4~20mA (Optional)
Accuracy	0.5%
Temperature Drift	50ppm/°C typical
Isolation Voltage	500Vdc
Open Circuit Voltage	15V

#### Analog Input (AI)

Input Range	0~5V/1~5V, 0~20mA/4~20mA (Optional)
Accuracy	0.2%
Temperature Drift	50ppm/°C typical
Isolation Voltage	500Vdc

#### Power Supply for DI (24Vdc)

Output Voltage	24Vdc
Output Current	42mA
Load (Max)	21 DI's

### OPERATING ENVIRONMENT

Operation Temperature	-25°C to 70°C
Storage Temperature	-40°C to 85°C
Relative Humidity	5% to 95% non-condensing

### STANDARD COMPLIANCE

Measurement Standard	IEC 62053-22; ANSI C12.20
Environmental Standard	IEC 60068-2
Safety Standard	IEC 61010-1, UL 61010-1
EMC Standard	IEC 61000-4/-2-3-4-5-6-8-11, CISPR 22
Outlines Standard	DIN 43700, ANSI C39.1

# TYPICAL WIRING

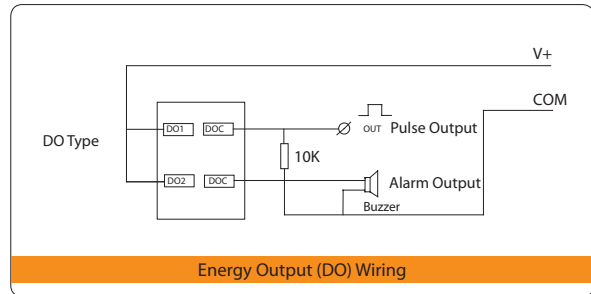
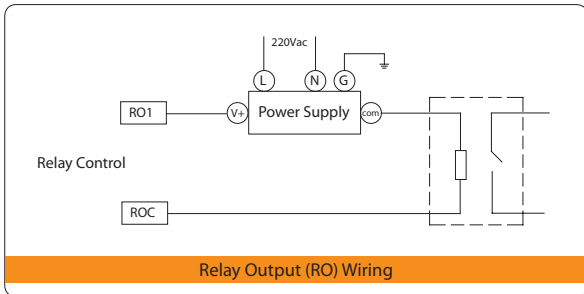
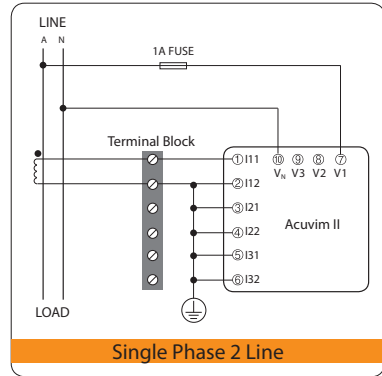
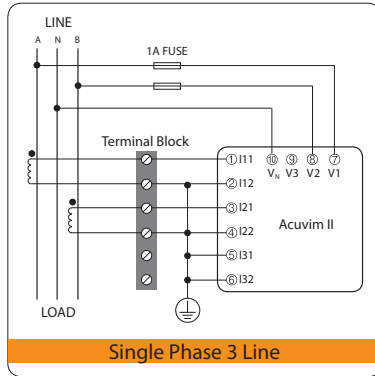
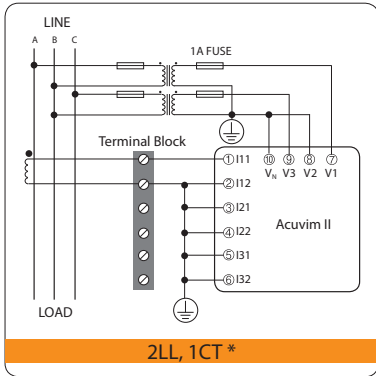
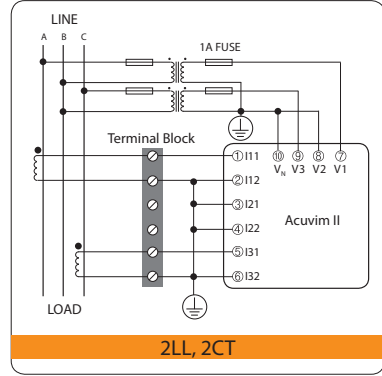
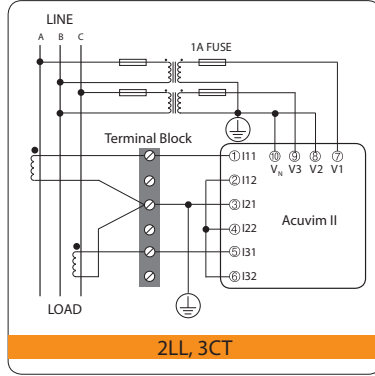
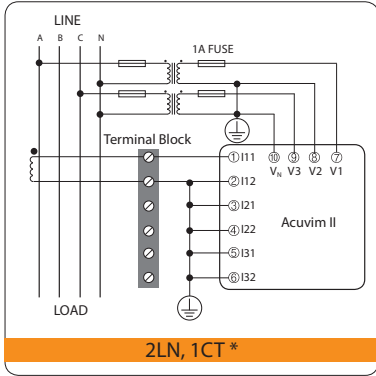
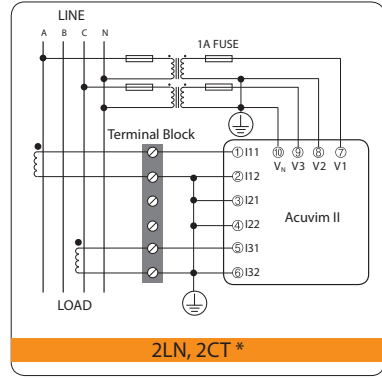
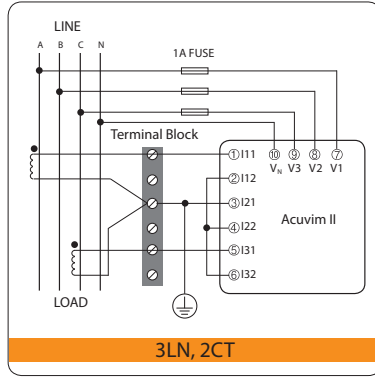
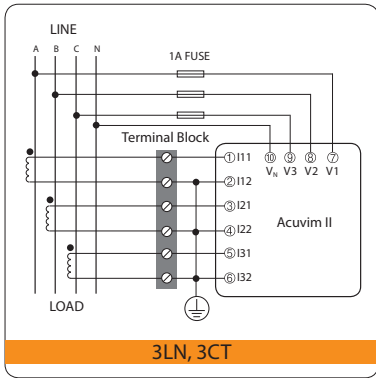

Note: "\*" wiring diagram not applicable to Acuvim IIR/IIE/IIW

# DIMENSIONS

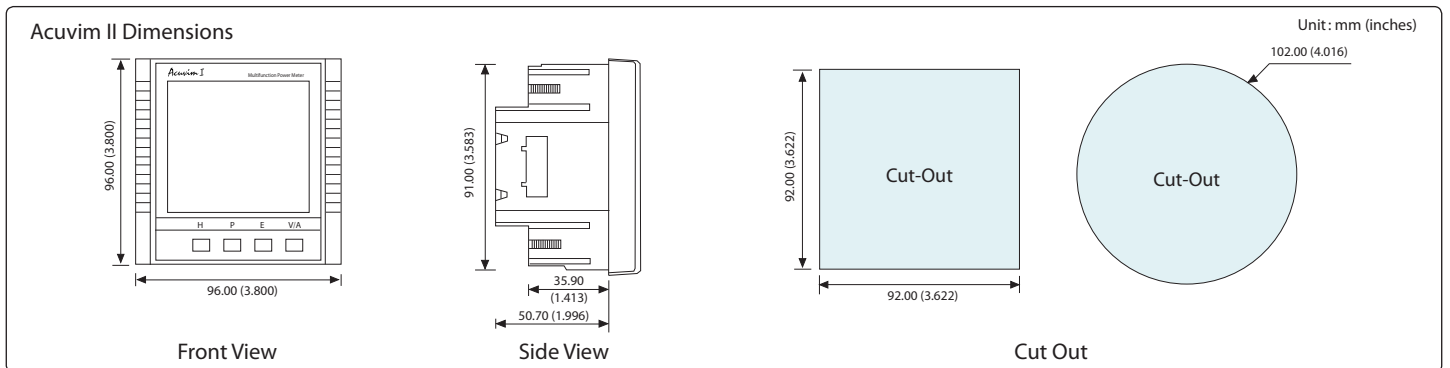

## DIMENSIONS

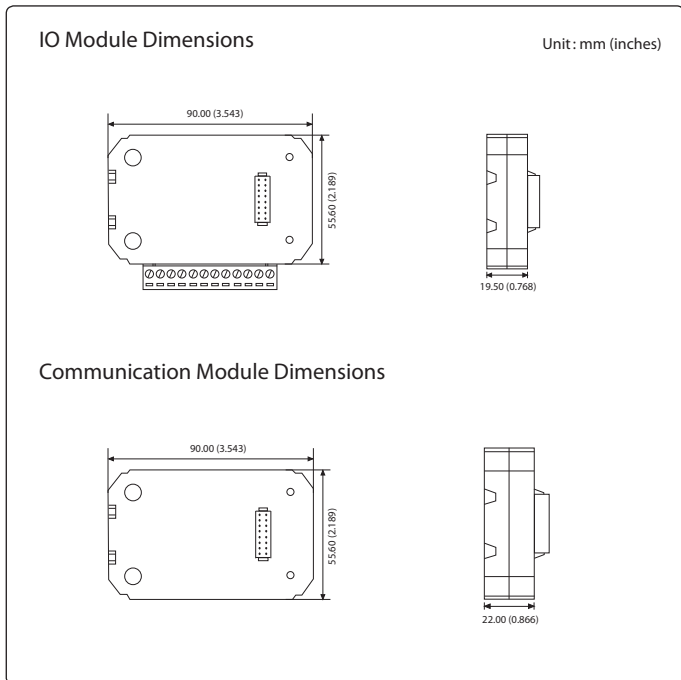
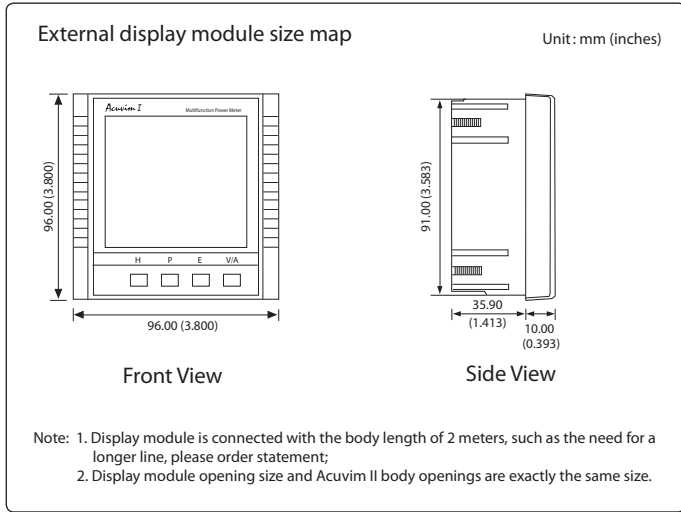
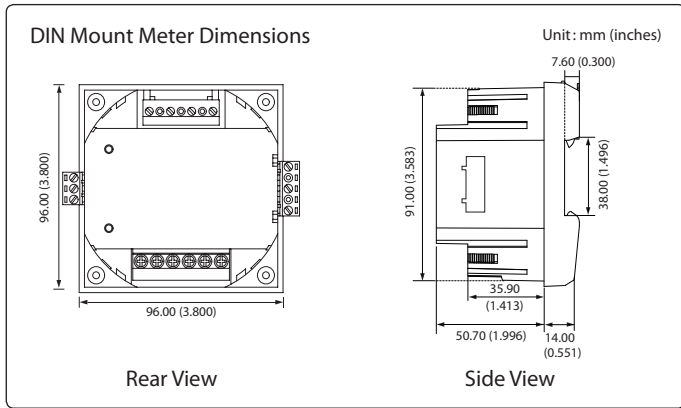

## ORDERING INFORMATION

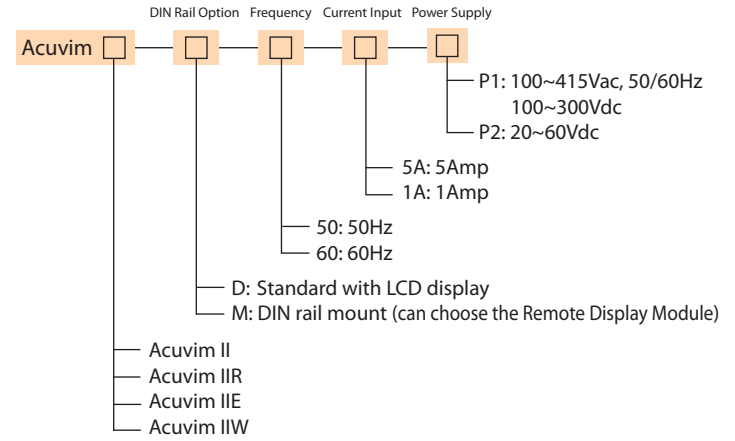

Acuvim II Base Meter Ordering Example: Acuvim IIR - D - 60 - 5A - P1

## I/O Option module

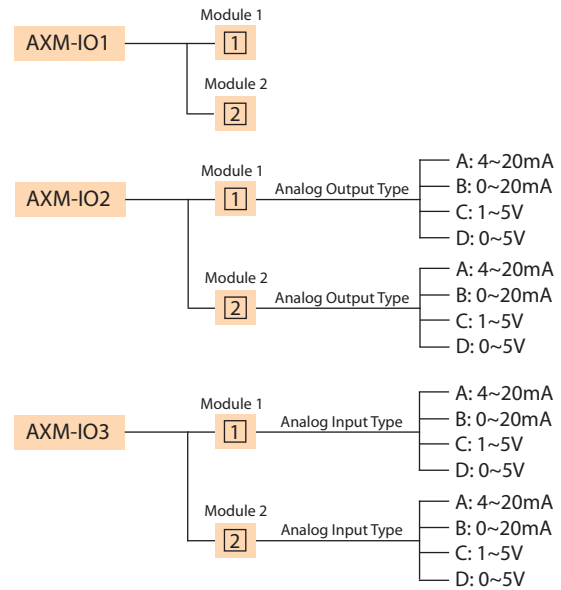

IO Module Ordering Example: AXM-IO2-1A

## Remote Display Option

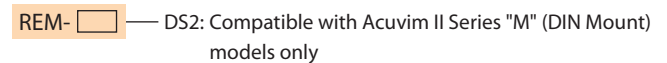

## Communication Option Module

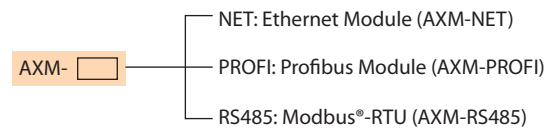

- Note: 1. No more than 2 of the same I/O modules may be attached to the meter (example: Two AXM-IO2). The same two IO modules must be a different component number.  
2. A maximum of 3 modules may be attached to the meter. If a communication module is used (example: A XM-NET), it must be installed on the back of the meter FIRST before the other module are attached.



Accuenergy Corp.

Los Angeles-Toronto-Beijing

North America Toll Free: 1-877-721-8908

Web: www.accuenergy.com

Email: marketing@accuenergy.com

Revision Date: Feb, 2012

Document #1040E1107